

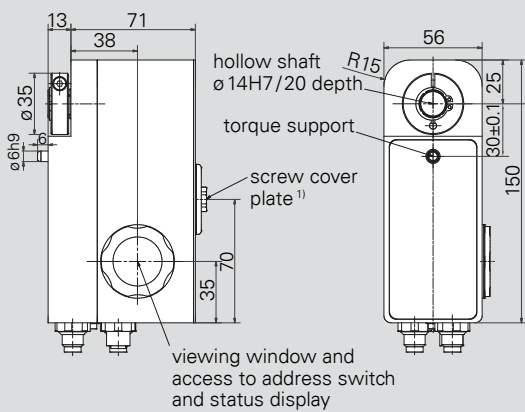

PSW 30_/32_-14 (with hollow shaft)

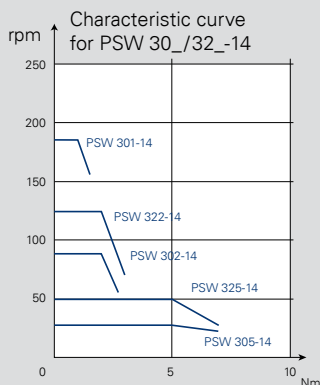

PSW 30_/32_-14-V (with solid shaft)

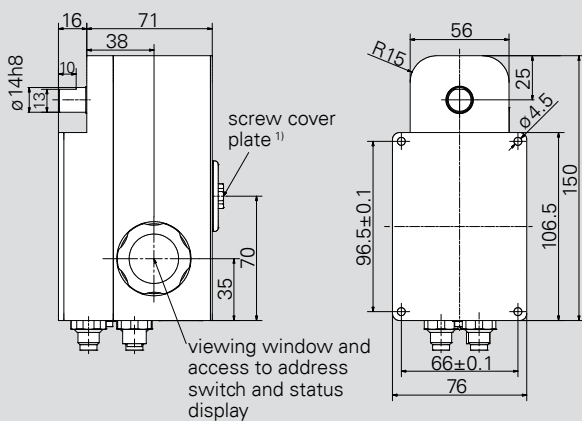

¹⁾ over a rotating manual adjustment shaft SW6/8 depth hex

All dimensions in mm.
For details of the connections please see also p. 47 and the instruction manual.

Product	Nominal torque	Self-holding torque	Nominal rated speed
PSW 301-14	1 Nm	0.5 Nm	180 rpm
PSW 302-14	2 Nm	1 Nm	90 rpm
PSW 305-14	5 Nm	2.5 Nm	35 rpm
PSW 322-14	2 Nm	1 Nm	125 rpm
PSW 325-14	5 Nm	2.5 Nm	50 rpm

Data interfaces

CANopen, PROFIBUS DP, DeviceNet, Modbus RTU, Sercos, EtherCAT, PROFINET, EtherNet/IP, POWERLINK, IO-Link

Duty cycle	20 % (basis time 600s) at nominal torque
Mode of operation	S3
Supply voltage	24 VDC ± 10 % galvanically separated between control and motor and bus
Nominal current	PSW 30_: 2.4 A, PSW 32_: 3.1 A
Power consumption (control unit)	0.1 A
Positioning accuracy absolute measurement of position taken directly at the output shaft	0.9°
Positioning range	250 rotations not subject to mechanical limits
Shock resistance in accordance with IEC/DIN EN 60068-2-27	50g 11 ms
Vibration resistance in accordance with IEC/DIN EN 60068-2-6	10..55 Hz 1.5 mm/ 55..1 000 Hz 10 g/ 10..2 000 Hz 5 g
Output shaft	14 mm solid shaft or 14 mm hollow shaft with adjustable collar
Snap-on brake	optional (holding torque = nominal torque)
Maximum axial force	20 N
Maximum radial force	40 N
Ambient temperature	0..45 °C
Storage temperature	-10..70 °C
Protection class	IP68 at standstill ¹⁾ , IP66 during rotation (tested with water) ¹⁾
Material	stainless steel
Weight	1 200 g
Certificates	CE, optional: NRTL (UL, CSA, ANSI)

¹⁾ welded V2A housing, output shaft sealed with quad-ring

The order key and accessories can be found on p. 18 / 19.



Product	Nominal torque	Self-holding torque	Nominal rated speed
PSW 3210-14	10 Nm	5 Nm	24 rpm
PSW 3218-14	18 Nm	9 Nm	14 rpm

Data interfaces
 CANopen, PROFIBUS DP, DeviceNet, Modbus RTU, Sercos, EtherCAT, PROFINET, EtherNet/IP, POWERLINK, IO-Link

Duty cycle	20 % (basis time 600 s) at nominal torque
Mode of operation	S3
Supply voltage	24 VDC ± 10 % galvanically separated between control and motor and bus
Nominal current	2.2 A
Power consumption (control unit)	0.1 A
Positioning accuracy absolute measurement of position taken directly at the output shaft	0.9°
Positioning range	250 rotations not subject to mechanical limits
Shock resistance in accordance with IEC/DIN EN 60068-2-27	50 g 11 ms
Vibration resistance in accordance with IEC/DIN EN 60068-2-6	0..55 Hz 1.5 mm / 55..1 000 Hz 10g / 10..2 000 Hz 5g
Output shaft	14 mm hollow shaft with adjustable collar
Snap-on brake	optional (holding torque = nominal torque)
Maximum axial force	20 N
Maximum radial force	40 N
Ambient temperature	0..45 °C
Storage temperature	-10..70 °C
Protection class	IP68 at standstill ¹⁾ , IP66 during rotation (tested with water) ¹⁾
Material	stainless steel
Weight	1350 g
Certificates	CE, optional: NRTL (UL, CSA, ANSI)

¹⁾ welded V2A housing, output shaft sealed with quad-ring

The order key and accessories can be found on p. 18 / 19.

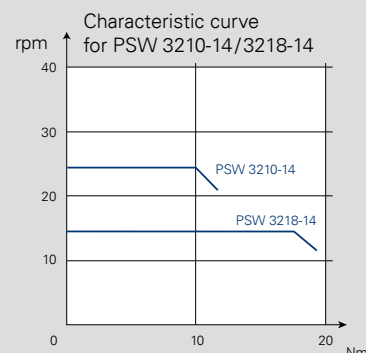
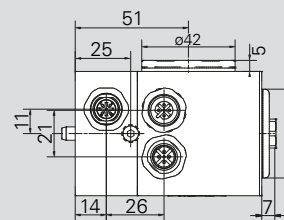
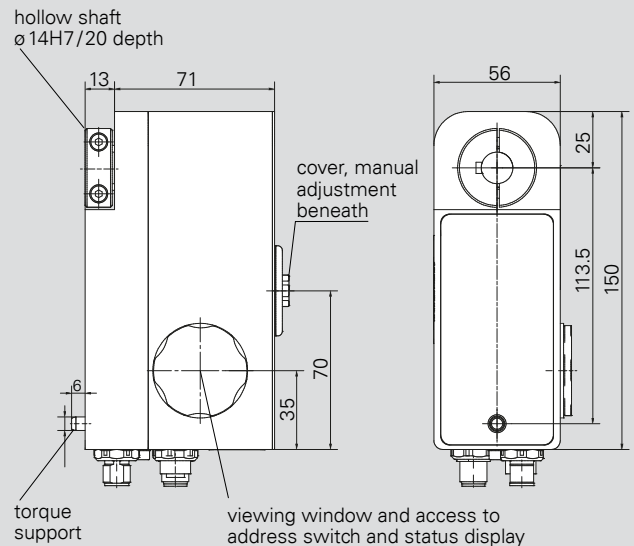

All dimensions in mm.
 For details of the connections please see also p. 47 and the instruction manual.

ORDER KEY PSE/PSS/PSW 3 SERIES

All the positioning systems in the PSE/PSS/PSW 3 series share the same order key.

To provide the best possible overview and to simplify customer documentation, the diverse range of options available for the PSE/PSS/PSW 3 series has been organised in a shared order key.

Order key

PSE/PSS/PSW:

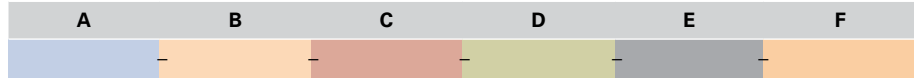

	Protection class	A Design	B Type	C Bus communication (see p. 7)	D Connections	E Brake (see p. 11)	F Certification
Positioning System Efficient (see p. 20-25) ¹⁾	IP 54	PSE		CA: CANopen DP: PROFIBUS DP DN: DeviceNet	0: standard T: with jog keys ³⁾		0: CE N: NRTL certification in accordance with UL, CSA, ANSI and CE
Positioning System Stainless (see p. 27-30)	IP 65	PSS	30x-8/-14 (V) ²⁾ 31x-8/-14 (V) ²⁾ 32x-14 (V) ²⁾ 33x-14 (V) ²⁾	MB: Modbus RTU SE: Sercos EC: EtherCAT PN: PROFINET EI: EtherNet/IP PL: POWERLINK IO: IO-Link	Y: 1 connector, Y-encoded Z: 1 connector, Y-encoded, with jog keys ³⁾	0: without M ⁴⁾ : with	
Positioning System Washable (see p. 32-35)	IP 68	PSW					

¹⁾ You can find the order key for the PSE 34_-14 on page 26.

²⁾ (V) not for PSE

³⁾ not for PSW or IO-Link, always via an extra connector

⁴⁾ only with 14 mm output shafts

Standard equipment (connections)

- always provided with 3 plugs/sockets (not for IO-Link or Y-encoded connector)
- address switches always provided (also IE-buses, not for IO-Link)

For further information on connections and address settings see also "Overview: bus communication" on p. 47.

Form/Type	Torque	Output shaft
horizontal	30	8 = 8 mm hollow shaft
vertical	31	14 = 14 mm hollow shaft
horizontal	32	8V = 8 mm solid shaft ⁶⁾
vertical	33	14V = 14 mm solid shaft ⁶⁾

⁵⁾ only for PSE

⁶⁾ only for PSS/PSW

Examples of orders provided below.

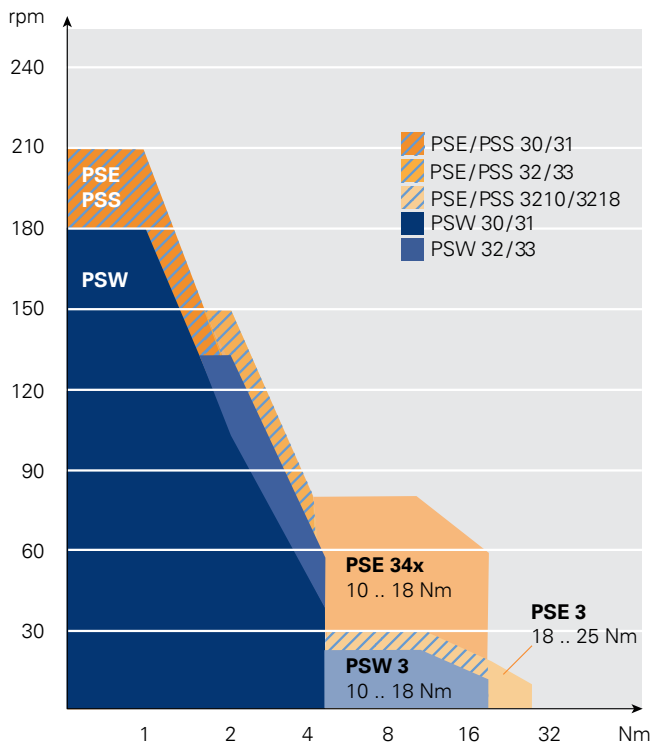

Nominal torque – nominal speed combinations

TORQUES AND SPEEDS

Example 1

You require the protection class IP54 and a maximum torque of 2 Nm. The speed should be greater than 100 rpm. An 8 mm hollow shaft and longitudinal construction meet the requirements of your application.

Your wish to use EtherNet/IP as the bus and connect the PSE to the control unit using a hybrid connector and hub. You do not require an additional holding brake in your application.

→ PSE 312-8-EI-Y-0-0

Example 2

IP68, max. 3 Nm, > 100 rpm, horizontal construction, 14 mm solid circular shaft, IO-Link via a connector, with brake.

→ PSW 325-14V-IO-0-M-0

ACCESSORIES PSE/PSS/PSW 3 SERIES

The connectors shown here can be used for all three types of device (PSE/PSS/PSW). This ensures that the PSE (IP54) and PSS (IP65) comply with the IP protection classes. We will also be pleased to help you find a suitable mating connector for the PSW (IP68) if necessary – just ask us!

Bus communication	Power supply + databus connector (2x) (for option 0) ¹⁾	Power supply + databus (2x) + jog key connector (for option T, not for PSW) ¹⁾	Cable and connectors for 1-connector solution ²⁾ (for option Y or IO-Link) ¹⁾
CANopen ³⁾	 Connector set: Order no. 9601.0060	 Connector set: Order no. 9601.0062	 5 m: Order no. 9601.0245 10 m: Order no. 9601.0233 20 m: Order no. 9601.0234
PROFIBUS DP			
Modbus RTU			
DeviceNet	 Connector set: Order no. 9601.0088	 Connector set: Order no. 9601.0090	
Sercos	 Connector set: Order no. 9601.0112	 Connector set: Order no. 9601.0317	5 m: Order no. 9601.0240 10 m: Order no. 9601.0244
EtherCAT			Hub on request
PROFINET			
EtherNet/IP			
POWERLINK			
IO-Link ³⁾	-	-	 Connector: Order no. 9601.0107 ²⁾

¹⁾ see under "D" in the order key ²⁾ power supply and bus via one cable, without second databus connector

⁴⁾ A- or B- coding of the connectors is possible

Further Accessories



Jog key box (for option T, not for PSW)
Order no. 9601.0241



Screw cap to cover the second bus connection (for PSS/PSW) **Order no. 9601.0176**

MODULES AND DESCRIPTION FILES

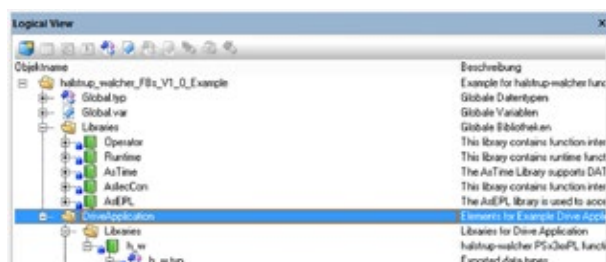

Take advantage of our functional modules or description files for the various buses. You can download the files on our website:

www.halstrup-walcher.de/en/software